



2013 SHERBROOKE CANADA SUMMER GAMES BASKETBALL TECHNICAL PACKAGE

Technical Packages are a critical part of the Canada Games. They guide the selection of athletes by prescribing the age and eligibility requirements, assist the organizing committees by detailing tournament formats and scoring procedures, assist Chefs de Mission in verifying eligibility, help with budgeting by describing the number of participants permitted, advance coaching certification by stating minimum requirements and generally contribute to athlete development by identifying each National Sport Organization's (NSO) version of athletes in the "training to compete" phase of its Long Term Athlete Development Model (LTAD), or other suitable phase of the model as justified by the NSO, discussed with the LTAD expert group, and approved by the Canada Games Council Sport Committee.

Every Games' coach, manager, Sport Chairperson and Mission staff has an obligation to read and understand every aspect of the Technical Package. Failure to do so could cost an athlete his or her eligibility for the Games or could affect final standings or the conduct of the competition. If someone does not understand an aspect of a Technical Package, he or she is to seek clarification from the Sport Committee of the Canada Games Council (CGC) through his or her Chef de Mission or NSO.

Technical Packages are developed primarily by NSOs, following principles outlined in this document, guidelines and requirements of the CGC. As the overall governing body of the Games, the CGC has the ultimate authority over Technical Packages, but this authority is exercised only with the knowledge and understanding of the concerned NSO.

If an individual wishes to seek clarification or initiate a change to a Technical Package leading up to a Games, the request should be first directed to the NSO or the Chef de Mission. The NSO or Chef de Mission will evaluate the merits of the request and will, if it has merit, submit the requested change or clarification to the CGC's Director of Sport for consideration. The NSO or Chef de Mission will submit the rationale for the request. Changes to age groups, eligibility requirements, team sizes or staff complements will not be considered after three years prior to the Games. Substantive changes to events or competition formats will not be considered after 18 months before the Games, unless approved by all participating provincial/territorial associations, the CGC, and the Host Society. Minor corrections will be considered at almost anytime, but will be increasingly difficult to achieve within six months of the Games. These time frames reinforce the importance of complete understanding of the Technical Package by Games' participants early.

— National Partners/ Partenaires nationaux —



**2013 SHERBROOKE CANADA SUMMER GAMES
TECHNICAL PACKAGE**

1. SPORT: BASKETBALL

2. COMPETITORS:

2.1 Competitors: Male 12 Female 12

2.2 Staff:
men's team: 2 Coaches and 1 Manager,
At least one of the coaches must be male

women's team: 2 Coaches and 1 Manager
At least one of the coaches must be female, if the head
coach is male; then the manager must also be female

3. CLASSIFICATION:

AB, BC, MB, NB, NF, NS, ON, QC, SK:

- Under 17 as of December 31, 2012
- Year of Birth: 1996 or later.

NT, NU, PE, YT

- Under 17 as of December 31, 2012 plus a maximum of two (2) players under 18 as of December 31, 2012.
 - Year of Birth: 1996 or later plus a maximum of two (2) players born in 1995.
-

4. ELIGIBILITY:

4.1 Coaches:

Any staff listed as coaches on the official registration form must be fully certified under the National Coaching Certification Program to at least Level III or the new NCCP equivalent, Competition stream, Development context (Certified status) in Basketball. These coaches must be so certified not later than 180 days before the opening of the Games (February 3, 2013).

4.2 Competitors:

None.

5. **COMPETITION:** FIBA RULES - ROUND ROBIN POOL

5.1 Tournament Format/Seeding

- (a) The competition shall be played in **two to four pools** with round robin play in each **pool**. Teams will then get reseeded and move into a single elimination consolation as outlined in Section 5.4 - Competition Template
- (b) **Pool** seeding for the Competition is based on the Competition Template outlined below (Section 5.4).
- (c) Pool seeding is based on the results of the 2012 National Juvenile Championships.
- (d) Provinces or territories not attending the 2012 National Juvenile Championships shall be ranked and seeded by Canada Basketball. In determining pool placement consideration shall be given to ensure that the pools are competitively balance.

5.2 Tournament Rules

- (a) All games shall be played under FIBA rules
- (b) The rules shall be reviewed at the conclusion of the 2012 Olympic Games to ensure that the competition rules are consistent with FIBA rules changes which have been approved by FIBA.

5.3 Application of Policies

- (a) Conduct or discipline infractions which occur on the field of play shall be dealt with pursuant to the rules of FIBA and Canada Basketball
- (b) Conduct or discipline infractions which occur off the field of play shall be dealt with under the auspices of the Canada Games Council pursuant to the guidelines, policies and procedures as provided by the Canada Games Council.

5.4 Competition Template

- (a) Round Robin Play
As outlined in section 5.1, the provincial/territorial teams (Male & Female) shall be seeded into two to four pools as follows:

8 teams - Pool A 1, 2, 3, 4

Pool B 5, 6, 7, 8

9 teams - Pool A 1, 2, 3, 4

Pool B 5, 6, 7, 8, 9

10 Teams - Pool A 1, 6, 9

Pool B 2, 5, 8, 10 Pool C 3, 4, 7

11 Teams - Pool A 1, 6, 11 Pool B 2, 5, 8, 10 Pool C 3, 4, 7, 9
 12 (or 13) Teams - Pool A 1, 7, 12 Pool B 2, 8, 11
 Pool C: 3, 5, 10 Pool D: 4, 6, 9, (13)

(b) Medal/Classification Round

8 Team Format

ALL 8 TEAMS MOVE INTO A SINGLE ELIMINATION CONSOLATION

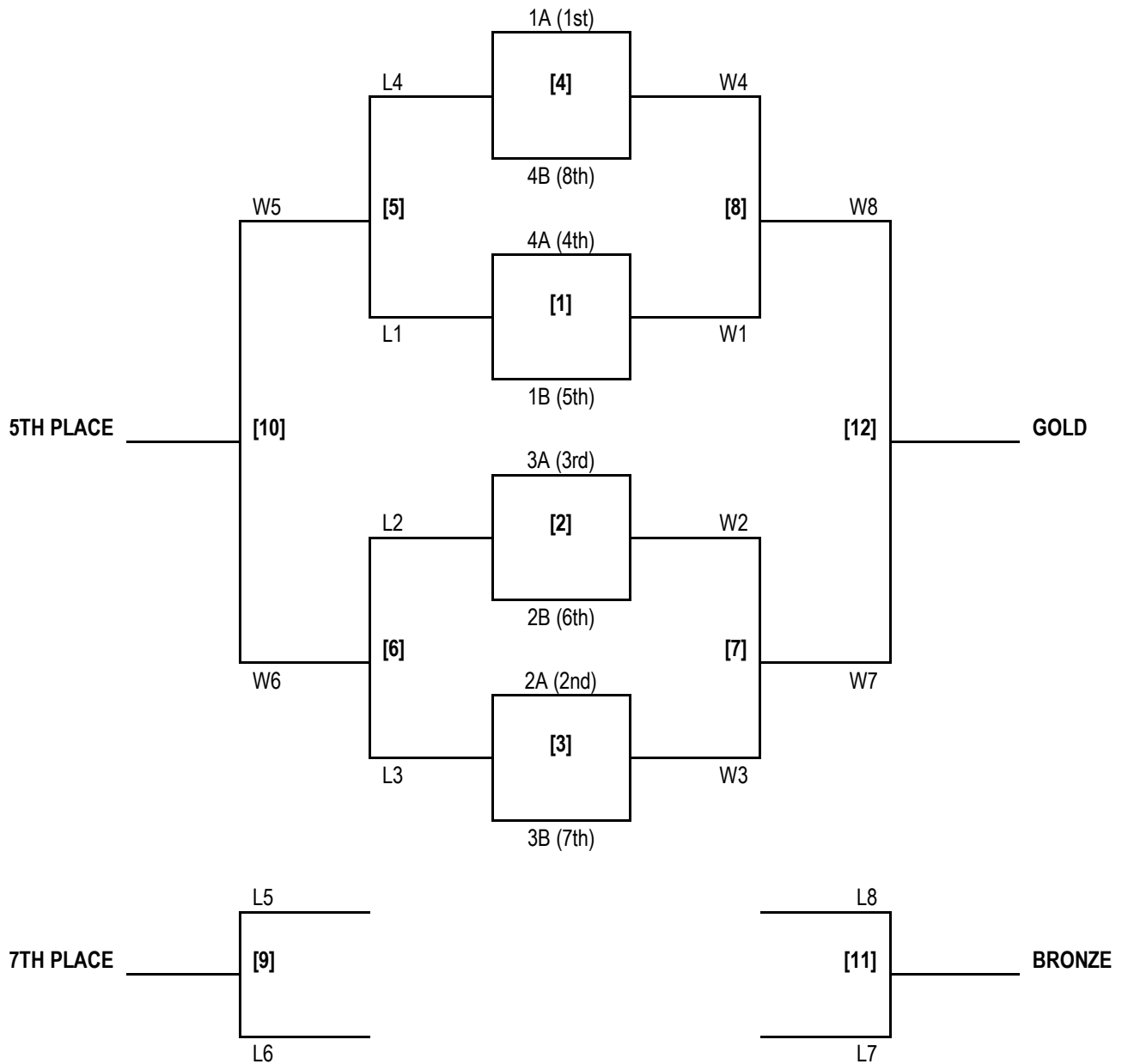

9 Team Format

TOP 6 TEAMS MOVE INTO A SINGLE ELIMINATION CONSOLATION

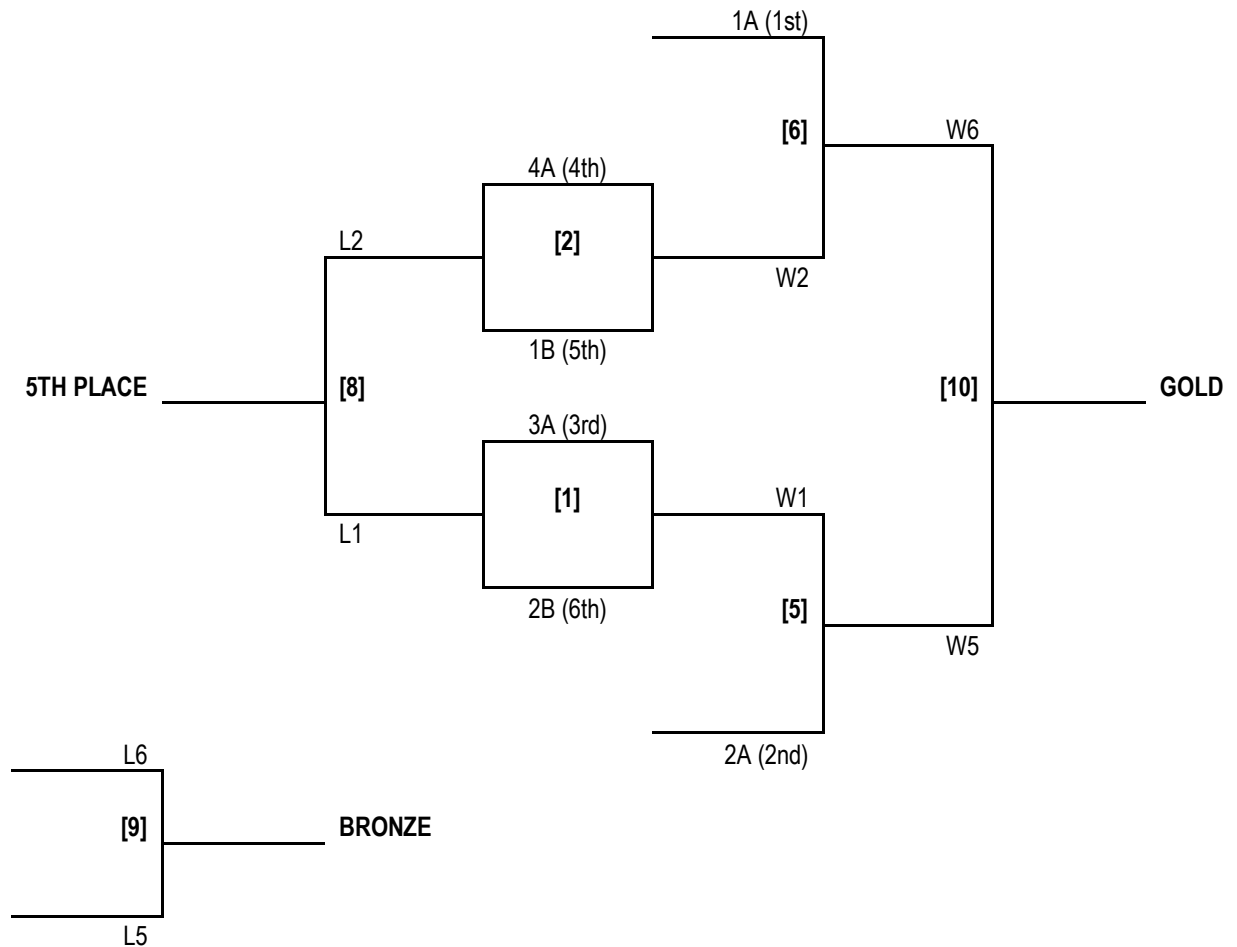

BOTTOM 3 TEAMS PLAY A ROUND ROBIN FOR PLACING

GAME #	TEAMS
[3]	3B vs 4B
[4]	5B vs 3B
[7]	4B vs 5B

TEAMS ELIMINATED FROM PLAYOFF ROUND PLAY ONE GAME FOR PLACING

GAME #	TEAMS
[11]	L18 vs L17

11 Team Format

TOP 8 TEAMS MOVE INTO A SINGLE ELIMINATION CONSOLATION

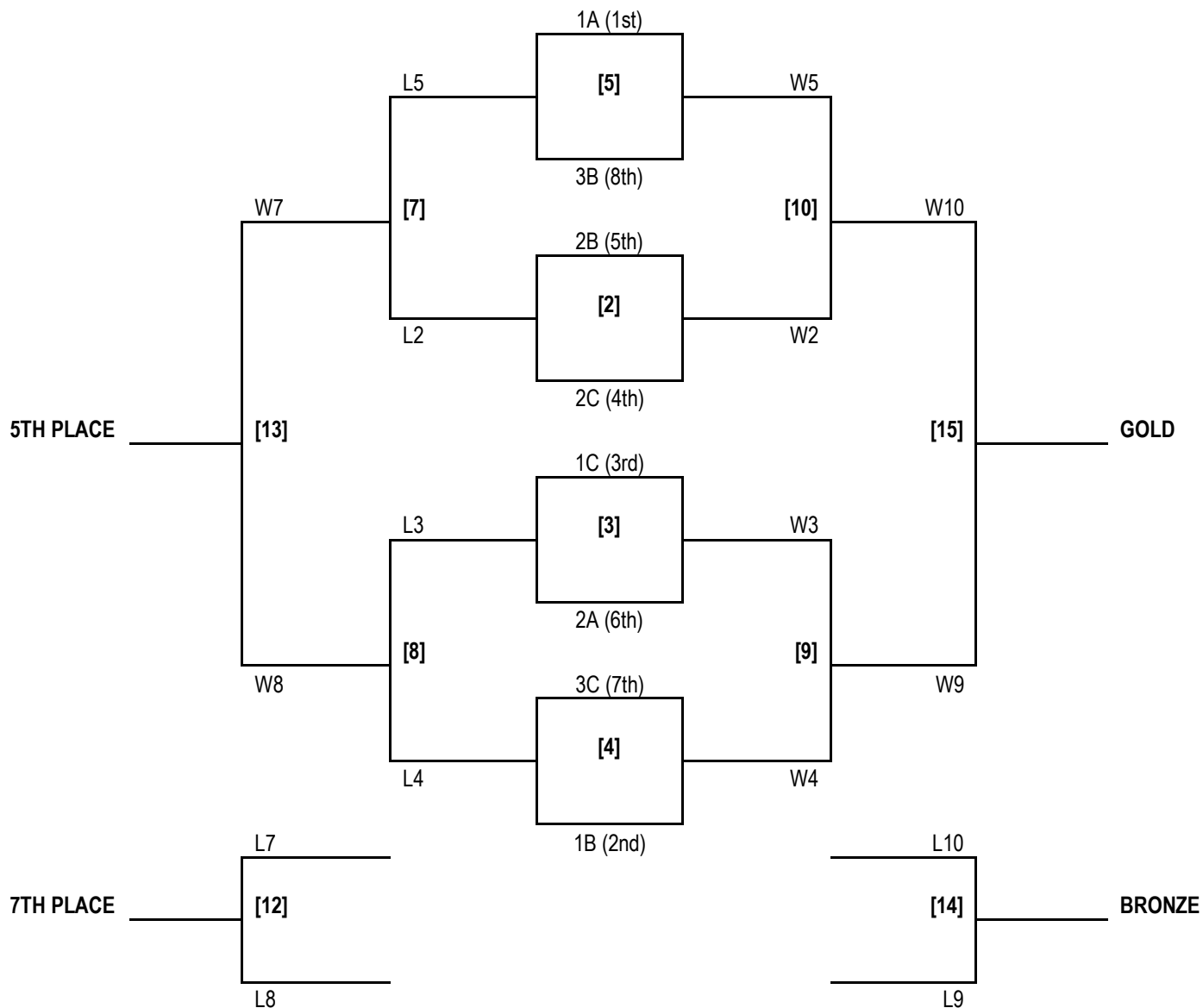

BOTTOM 3 TEAMS PLAY A ROUND ROBIN FOR PLACING

GAME #	TEAMS
[1]	3A vs 4B
[6]	4C vs 3A
[11]	4B vs 4C

12 Team Format

TOP 8 TEAMS MOVE INTO A SINGLE ELIMINATION CONSOLATION

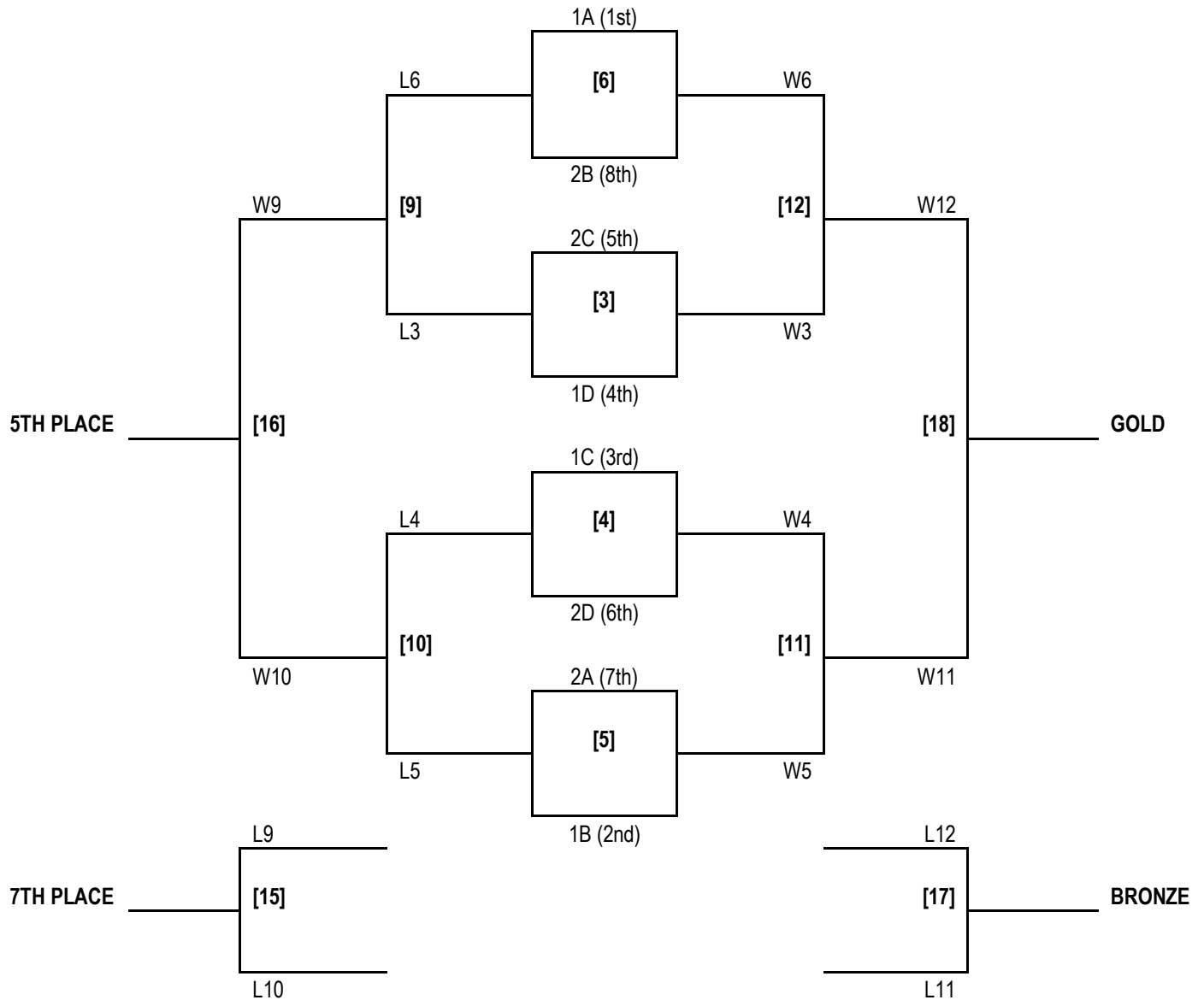

BOTTOM 4 TEAMS PLAY A ROUND ROBIN FOR PLACING

GAME #	TEAMS
[1]	3D vs 3A
[2]	3C vs 3B
[7]	3D vs 3C
[8]	3A vs 3B
[13]	3C vs 3A
[14]	3B vs 3D

- Sport Scoring will be attributed to results from the Round Robin for placing to determine final placing of 9th – 12th (or 13th).
- Ties will be broken using the FIBA tie-breaking procedure.

6. SPORT SCORING:

Win - 2 points

Loss - 1 point

Forfeit - 0 point

Per FIBA Rules – In the case of a forfeit of a game, the game shall be awarded to the opponent and the score shall be twenty to zero (20-0).

7. PROVINCIAL/TERRITORIAL RANKING (FLAG POINTS):

Following the final ranking of all teams, points for the Games Flag will be awarded as follows. Men and women are ranked separately.

Position	Points	Position	Points	Position	Points
1 st place	10	6 th place	5	11 th place	1.5
2 nd place	9	7 th place	4	12 th place	1
3 rd place	8	8 th place	3	13 th place	0.5
4 th place	7	9 th place	2.5		
5 th place	6	10 th place	2		

8. TIE BREAKING RULE - COMPETITION:

Tie Score and Extra Periods

If a score is a tie at the expiration of the second half, play shall be continued for an extra period of 5 minutes or as many such periods of 5 minutes as may be necessary to break the tie. An interval of 2 minutes shall be allowed before each extra period.

The classification of the teams in each group of a contest shall be made on points, according to their win-loss records, namely 2 points for each game won, 1 point for each game lost and 0 point for a game lost by forfeit. If at the end of a round some teams are equal with the same number of points, the following method will be used to determine the placings:

1. In the event two teams have the same number of points in the placings (based on win-loss records), the classification will be established taking into account only the result of the game between the two teams involved.
2. If more than two teams have equal points in the placings (based on win-loss records), a second classification will be established taking into account only the results of the games between the teams involved.
3. If the situation is not resolved and teams have equal points in the placings after the second classification, then goal average (by mathematical division), taking into account only the results of the games between the teams involved will be made to determine the classification.
4. If it is still not finally resolved, the classification will be determined by goal average, taking into account all the results of the games from the group in question.

NOTE: Goal average is determined by dividing points for by points against. The highest quotient is the winner.

A team which, without valid reason, fails to appear to play a scheduled game or withdraws from the court before the end of the game, shall lose the game by forfeit. The game shall be awarded to the opponent and the score shall be registered as twenty to zero (20 to 0) in favour of the opponent. The Technical Committee may, in addition, decide to relegate the team to the last place of the classification. This is automatically carried out in the event of recurrence by the same team. Nevertheless, the results of the games played by the team remain valid for the purpose of general classification of the contest.

9. PROVINCIAL/TERRITORIAL RANKING (FLAG POINTS) - TIE BREAKING:

No tie shall occur for Provincial/Territorial Ranking (Flag Points). Please see Tie-Breaking Rules for Competition (Section 8).

10. MEDALS:	MALE:	GOLD: 12	SILVER: 12	BRONZE: 12
	FEMALE:	GOLD: 12	SILVER: 12	BRONZE: 12

11. COMPETITIVE UNIFORMS:

Athletes

Provincial/Territorial colours must be worn. In the event that team uniform colours are similar and may cause confusion, the designated "Home" team must be prepared to change into an alternate set of uniforms. The uniforms must comply to FIBA rules, this includes the numbers. The official uniform numbers are 4-15. The alternate jerseys are designated 20-25. The alternate jerseys are only to be worn in the case of a lost or blood stained jersey.

In order to have the Canada Games run in a professional matter ALL ATHLETES are required to wear their Provincial/Territorial team uniform at all times while on the field of play (including benches). Coaches are responsible to ensure their players are dressed respectfully at all times. Athletes failing to adhere to this rule will be removed from the field of play.

Staff

In order to have the Canada Games run in a professional matter ALL BENCH STAFF (coaches / trainers / managers) will have to adhere to the following guidelines regarding attire.

These guidelines shall be distributed to all participating teams no later than 45 days in advance of the tournament. Canada Basketball to send guidelines to Provincial Territorial Sport Organizations 60 days prior to event.

Dress will be summer business casual. Items that we recommend be worn on the bench include:

- Golf Shirts and Polo Shirts (preferably with Provincial/Territorial Logo)
- Dress Pants / Shorts
- Shoes / Sneakers

Items that are forbidden on the bench include:

- Sport Sandals
- Thong Shoes (flip flops)
- Athletic Shorts
- Tank Tops
- Hats
- Cut Offs
- Jeans

Coaches should present a professional image while on the court at all events. Bench Staff whom does not follow these rules will be removed from the bench.

12. EQUIPMENT:

The official basketball of Canada Basketball will act as the official ball for the Canada Summer Games. Under no circumstances shall an alternate ball be substituted for games or practices.

13. APPENDIX:

The attached appendix forms an integral part of this technical package.

APPENDIX 1
2013 Sherbrooke Canada Summer Games

Competitor Eligibility

1. Competitors must meet all eligibility requirements outlined in the Technical Package.
2. The Canada Games are open to Canadian citizens and permanent residents.
3. The Canada Games are open to athletes who are members in good standing of their sport's NSO and/or Provincial/Territorial Sport Organization.
4. An athlete's permanent domicile or actual residence must be located, for at least the 180 days prior to the opening of the Games, within the recognized boundaries of the Province or Territory they are representing. An athlete can have only one domicile.
5. Students attending school on a full-time basis outside their province of permanent residence during the year of the Games shall be permitted to compete for either their province of permanent residence or the province in which the athlete attends school. To be eligible to compete for the province where the athlete attends school, the student must be enrolled on a full-time basis during the current academic year.
6. If a non-student athlete attends a recognized national training centre outside his or her Province of permanent residence, the athlete is encouraged to represent his or her province of Permanent residence; however, the athlete could represent the province where the centre is located under the terms of paragraph (7), below.
7. Exceptions to the domicile requirement will be possible if the athlete can demonstrate a commitment to the province or territory she or he wishes to represent by such means as having been a member of a club or provincial/territorial sport organization in that province/territory for the entire previous competitive season, having represented that province or territory at a previous national or regional championship or having attended school full-time the previous academic year or having been a member of a recognized national training centre full-time during the previous 12 months. Other similar circumstances may be considered.
8. An athlete is permitted to try out for any province or territory of eligibility but can only try out for one province or territory per sport. (i.e. an athlete may try out for swimming for one province or territory but cannot try out for swimming in another province or territory. An athlete may try out for one province in swimming, and may try out for another province or territory in diving).
9. Athletes may only compete for one province or territory at a single Canada Games.
10. Athletes may not compete in two sports at one Canada Games if they are scheduled in the same week.

11. The eligibility of any athlete that is not clearly established by these rules and by the Technical Package shall be determined by the Sport Committee of the Council. Coaches or PSOs must bring forward any unclear cases to their Chef de Mission and to their NSO as early as possible before the competition for forwarding to the Sport Committee.
12. Where a team/province/Chef wishes to challenge the eligibility of an athlete on another provincial/ territorial team, it is expected that such a challenge will be made as soon as the protesting team knows that an athlete may be ineligible. Every effort must be made to ensure that protests on eligibility are lodged before an athlete competes.

Other

13. All teams are reminded of the Canada Games Council's regulations concerning advertising on uniforms: only the uniform manufacturer's name or trade mark logo may be worn on team competition uniforms to a maximum size of 60 square centimeters.
14. Canada Games rules do not allow team staff to practice as therapists, physicians or other medical or paramedical practitioners. The Host Society (organizing committee) is responsible for providing high quality medical care at a central clinic at the Athletes' Village and at competition and training venues. The Sport Medicine Council of Canada assists the Host Society by providing additional medical practitioners to ensure that French and English speaking and male and female persons are available, to ensure that sport specific medical expertise is available and to ensure that all regions of Canada are represented. Team staff will not be permitted to administer medical care to athletes.